

Diaphragm Valve, Metal

Construction

The GEMÜ 615 2/2-way diaphragm valve has a low maintenance piston actuator which can be controlled by inert gases. Normally Closed, Normally Open and Double Acting control functions are available. An optical position indicator is integrated as standard.

Features

- Suitable for inert and corrosive* liquid and gaseous media
- Insensitive to particulate media
- Valve body and diaphragm available in various materials and designs
- Compact design (ideal when space is at a premium)
- Versions according to ATEX on request

Advantages

- Hermetic separation between medium and actuator
- Optional flow direction
- Installation for an optimized draining is possible
- Optional accessories:
 - Stroke limiter
 - Electrical position indicators with microswitches or proximity switches

*see information on working medium on page 2



Sectional drawing

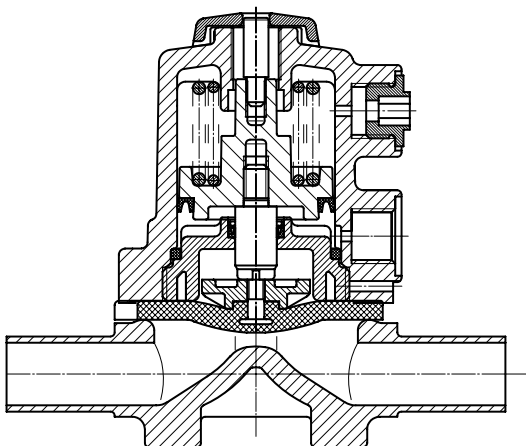

Technical data

Working medium

Corrosive, inert, gaseous and liquid media which have no negative impact on the physical and chemical properties of the body and diaphragm material.

Temperatures

Media temperature	-10 ... 80 °C
Ambient temperature	0 ... 60 °C

Control medium

Inert gases

Max. perm. temperature of control medium	40 °C
Filling volume	0.02 dm ³

Diaphragm size	Operating pressure [bar]		Control pressure [bar]		
	EPDM/FPM	PTFE	C.f. 1	C.f. 2	C.f. 3
10	0 - 6	0 - 6	5 - 7	max. 5.5	max. 5.0

All pressures are gauge pressures. Operating pressure values were determined with static operating pressure applied on one side of a closed valve. Sealing at the valve seat and atmospheric sealing is ensured for the given values. Information on operating pressures applied on both sides and for high purity media on request.

Diaphragm size	DN	Kv values [m ³ /h]					
		DIN Code 0	DIN 11850 series 1 Code 16	DIN 11850 series 2 Code 17	DIN 11850 series 3 Code 18	ASME BPE Code 59	EN ISO 1127 Code 60
10	10	-	2.4	2.4	2.4	2.2	3.3
	15	3.3	3.8	3.8	3.8	2.2	4.0
	20	-	-	-	-	3.8	-

Kv values determined acc. to IEC 534 standard, inlet pressure 6 bar, Δp 1 bar, stainless steel valve body and soft elastomer diaphragm.

Control pressure/operating pressure diagram

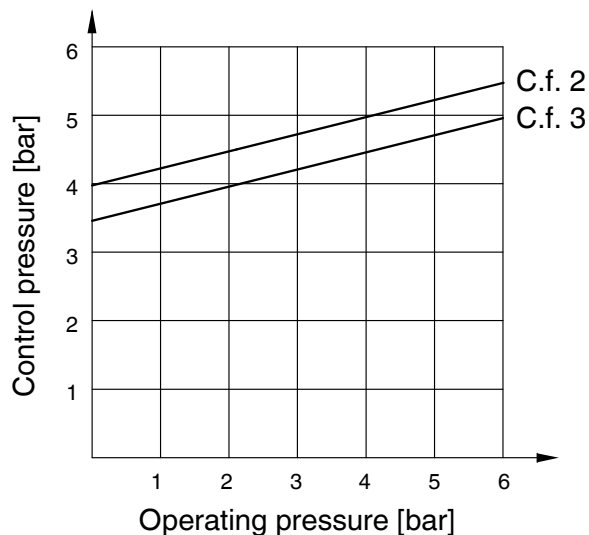

Order data

Body configuration	Code
2/2-way body	D

Connection	Code
Butt weld spigots	
Spigots DIN	0
Spigots DIN 11850, series 1	16
Spigots DIN 11850, series 2	17
Spigots DIN 11850, series 3	18
Spigots DIN 11866, series A	1A
Spigots DIN 11866, series B	1B
Spigots JIS-G 3459	36
Spigots BS 4825, part 1	55
Spigots ASME BPE	59
Spigots EN ISO 1127	60
Spigots ANSI/ASME B36.19M, Schedule 10s	63
Spigots ANSI/ASME B36.19M, Schedule 40s	65
Threaded connections	
Threaded sockets DIN ISO 228	1
Threaded spigots DIN 11851	6
One side threaded spigot, other side cone spigot and union nut, DIN 11851	62
Aseptic unions on request	
Clamp connections	
Clamps ASME BPE for pipe ASME BPE, length ASME BPE	80
Clamp DIN 32676 series B for pipe EN ISO 1127, length EN 558, series 7	82
Clamp ASME BPE for pipe ASME BPE, length EN 558, series 7	88
Clamps DIN 32676 series A for pipe DIN 11850, length EN 558, series 7	8A
For overview of available valve bodies for GEMÜ 615 see page 8.	

Valve body material	Code
CW617N (Brass)	12
1.4435 - BN2 (CF3M), investment casting Fe<0.5%	32
1.4435 (ASTM A 351 CF3M \triangleq 316L), investment casting	34
1.4408, investment casting	37
1.4435 (316 L), forged body	40
1.4435 (BN2), forged body Fe<0.5%	42

Diaphragm material	Code
FPM	4
EPDM	13
EPDM	14
EPDM	17
PTFE/EPDM, PTFE laminated	52
Material complies with FDA requirements, except code 4 and 14	

Control function	Code
Normally closed (NC)	1
Normally open (NO)	2
Double acting (DA)	3

Actuator size	Code
Standard version	1/N

Surface finish	Code
See top of page 4	

Order example	615	15	D	60	34	17	1	1/N	1500
Type	615								
Nominal size		15							
Body configuration (code)			D						
Connection (code)				60					
Valve body material (code)					34				
Diaphragm material (code)						17			
Control function (code)							1		
Actuator size (code)								1/N	
Surface finish (code)									1500

Order data

Valve body surface finish, internal contour

		Forged body Code 40, 42	Investment casting Code 32, 34	Code
Ra ≤ 6.3 µm	blasted internal/external	-	X	1500
Ra ≤ 6.3 µm	optical electropolishing	-	X	1509
Ra ≤ 0.8 µm	mechanically polished internal, blasted external	X	X	1502
Ra ≤ 0.8 µm	electropolished internal/external	X	-	1503
Ra ≤ 0.6 µm	mechanically polished internal, blasted external	X	X	1507
Ra ≤ 0.6 µm	electropolished internal/external	X	-	1508
Ra ≤ 0.4 µm	mechanically polished internal, blasted external	X	-	1536
Ra ≤ 0.4 µm	electropolished internal/external	X	-	1537
Ra ≤ 0.25 µm	mechanically polished internal, blasted external	X	-	1527
Ra ≤ 0.25 µm	electropolished internal/external	X	-	1516

Ra acc. to DIN 4768; at defined reference points
Surface finish data refer to medium wetted surfaces

Dimensions [mm]

Actuator dimensions

Diaphragm size	A	A1	A2	∅ B	B1	B2	G	Weight [kg]
10	80	21	30	57	35	68	G 1/4	0.18

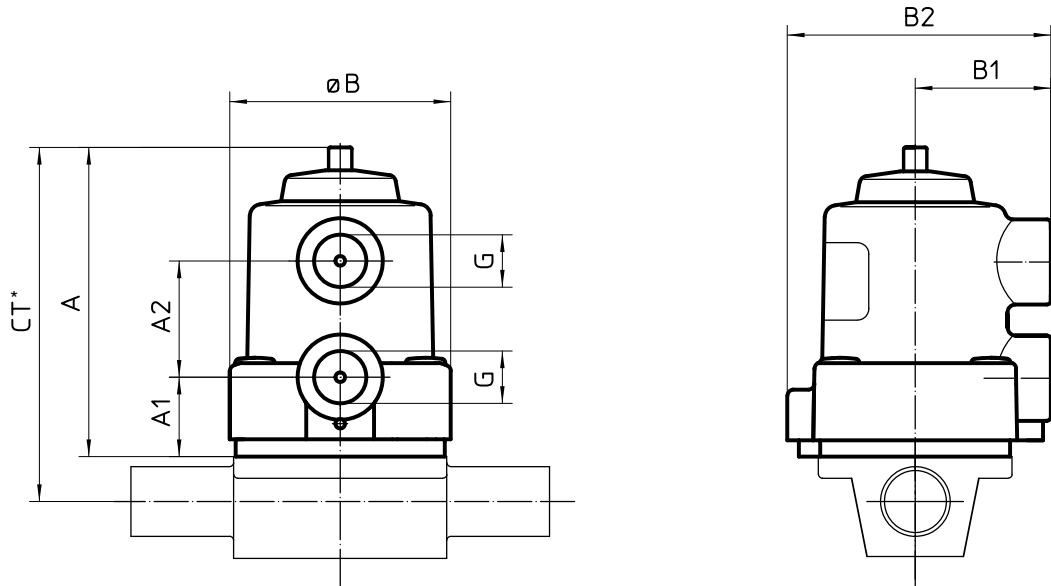

* CT = A + H1 (see body dimensions)

Body dimensions [mm]

Threaded sockets, connection code 1 Valve body material: investment casting (code 37)

MG	DN	R	H	H1	t	L	SW2	Number of flats	Weight [kg]
10	12	G 3/8	25	13	12	55	22	2	0.17
	15	G 1/2	30	15	15	68	27	2	0.26

MG = diaphragm size

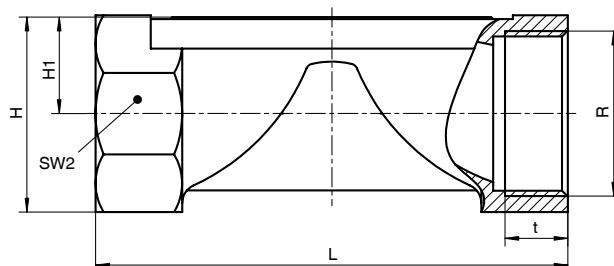

Body dimensions [mm]

Butt weld spigots, connection code 0, 16, 17, 18 Valve body material: investment casting (code 34), forged body (code 40)

								DIN Series 0 Code 0		DIN 11850 Series 1 Code 16		DIN 11850 Series 2 Code 17		DIN 11850 Series 3 Code 18		Weight [kg]
MG	DN	NPS	f*	øg*	L	c	H1	ød	s	ød	s	ød	s	ød	s	
10	10	3/8"	30	13.5	108	25	12.5	-	-	12	1.0	13	1.5	14	2.0	0.30
	15	1/2"	30	13.5	108	25	12.5	18	1.5	18	1.0	19	1.5	20	2.0	0.30
	20	3/4"	30	13.5	108	25	12.5	-	-	-	-	-	-	-	-	0.30

* only for investment cast design MG = diaphragm size For materials see overview on last page

Butt weld spigots. connection code 1A. 1B. 60 Valve body material: investment casting (code 34), forged body (code 40)

								DIN 11866 Series A Code 1A		DIN 11866 Series B Code 1B		EN ISO 1127 Code 60		Weight [kg]
MG	DN	NPS	f*	øg*	L	c	H1	ød	s	ød	s	ød	s	
10	10	3/8"	30	13.5	108	25	12.5	13	1.5	17.2	1.6	17.2	1.6	0.30
	15	1/2"	30	13.5	108	25	12.5	19	1.5	21.3	1.6	21.3	1.6	0.30
	20	3/4"	30	13.5	108	25	12.5	-	-	-	-	-	-	0.30

* only for investment cast design MG = diaphragm size For materials see overview on last page

Butt weld spigots. connection code 36. 55. 59. 63. 65 Valve body material: investment casting (code 34), forged body (code 40)

								JIS-G 3459 Code 36		BS 4825 Code 55		ASME BPE Code 59		ANSI/ASME B36.19M 10s Code 63		ANSI/ASME B36.19M 40s Code 65		Weight [kg]
MG	DN	NPS	f*	øg*	L	c	H1	ød	s	ød	s	ød	s	ød	s	ød	s	
10	10	3/8"	30	13.5	108	25	12.5	17.3	1.65	9.53	1.2	9.53	0.89	17.1	1.65	17.1	2.31	0.30
	15	1/2"	30	13.5	108	25	12.5	21.7	2.10	12.70	1.2	12.70	1.65	21.3	2.11	21.3	2.77	0.30
	20	3/4"	30	13.5	108	25	12.5	-	-	19.05	1.2	19.05	1.65	-	-	-	-	0.30

* only for investment cast design MG = diaphragm size For materials see overview on last page

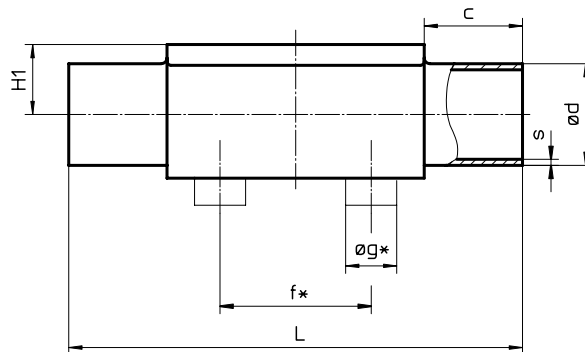

Body dimensions [mm]

Threaded connections, connection code 6, 62
Valve body material: investment casting (code 34), forged body (code 40)

MG	DN	H1	f*	øg*	ød1	Thread to DIN 405 R	Code 6 L	Code 62 L	Weight [kg]
10	10	12.5	30.0	13.5	10.0	RD 28 x 1/8	118	116	0.33
	15	12.5	30.0	13.5	16.0	RD 34 x 1/8	118	116	0.35

* only for investment cast design

MG = diaphragm size

For materials see overview on last page

Code 6

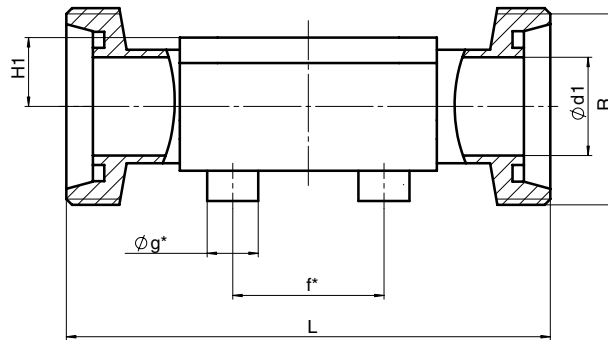

Code 62

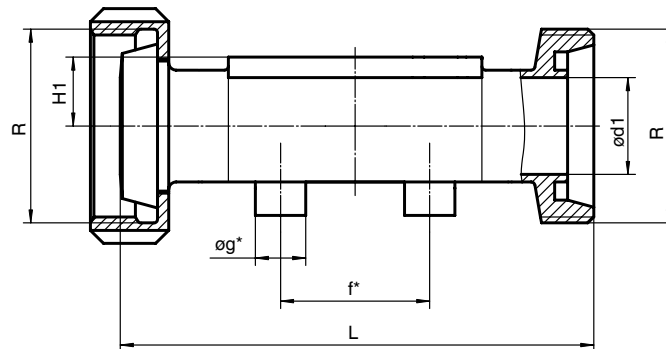

Body dimensions [mm]

Clamp connections, connection code 80, 82, 88, 8A Valve body material: forged body (code 40)

				for pipe ASME BPE Code 80			for pipe EN ISO 1127 Code 82			for pipe ASME BPE Code 88			for pipe DIN 11850 Code 8A			Weight [kg]
MG	DN	NPS	H1	ød1	ød3	L	ød1	ød3	L	ød1	ød3	L	ød1	ød3	L	
10	10	3/8"	12.5	-	-	-	14.0	25.0	108	-	-	-	10	34.0	108	0.30
	15	1/2"	12.5	9.40	25.0	88.9	18.1	50.5	108	9.40	25.0	108	16	34.0	108	0.43
	20	3/4"	12.5	15.75	25.0	101.6	-	-	-	15.75	25.0	117	-	-	-	0.43

MG = diaphragm size

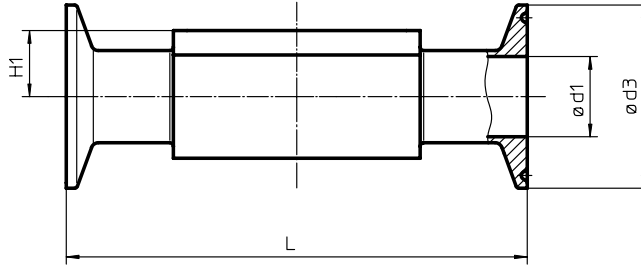

Overview of valve bodies for GEMÜ 615

		Threaded connections						Spigots																Clamps								
Connection code		1	6	62	0	16	17	18	1A	1B	36	55	59	60	63	65	80	82	88	8A												
Material code		12	37	34	40	34	40	34	40	34	40	34	40	40	40	40	40	40	40	40	40	40	40	40	40	40	40					
MG	DN																															
10	10	-	-	W	W	W	W	-	-	X	X	X	X	X	X	X	X	X	X	X	X	X	X	X	X	X	X	X	-	K	-	K
	12	X	X	-	-	-	-	-	-	-	-	-	-	-	-	-	-	-	-	-	-	-	-	-	-	-	-	-	-	-	-	
	15	X	X	W	W	W	W	X	X	X	X	X	X	X	X	X	X	X	X	X	X	X	X	X	X	X	X	X	K	W	K	K
	20	-	-	-	-	-	-	-	-	-	-	-	-	-	-	-	-	-	-	-	-	-	-	-	-	-	-	-	-	-	-	

X = Standard

K = Connections completely machined (not welded)

W = Welded construction

MG = diaphragm size

Availability of material code 32: same as code 34

For further metal diaphragm valves, accessories and other products,
please see our Product Range catalogue and Price List.
Contact GEMÜ.

GEMÜ® VALVES, MEASUREMENT
AND CONTROL SYSTEMS

