

Diaphragm Valve, Metal

Construction

The new GEMÜ 660 2/2-way diaphragm valve was designed for dosing and filling a wide range of products.

All metallic actuator components are made of stainless steel. Normally closed, Normally open and Double acting control functions are available. The valve has an integrated stroke limiter and seal adjuster as well as an optical position indicator as standard.

Features

- Suitable for inert, corrosive*, liquid and gaseous media
- Valve body and diaphragm available in various materials and designs
- Compact design (ideal when space is at a premium)
- Various connections available
- CIP/SIP cleaning and sterilizing capabilities
- Versions according to ATEX on request

Advantages

- Optional flow direction
- Installation for an optimized draining is possible
- Stroke limiter and seal adjuster easy to adjust
- Precise stroke scale on the cover, can be fixed, 10 scale points per turn, one full turn corresponds to 1 mm stroke
- Improved sealing
- Distance sleeves for the diaphragm (not for steam applications)
- 2 control air connectors in flow direction, 4 control air connectors as an option, two of which are arranged across the flow direction
- Fast cycle duties due to minimized filling volume
- Reduced air consumption
- Mounting of electrical position indicators (as an option)

*see information on working medium on page 2

Sectional drawing

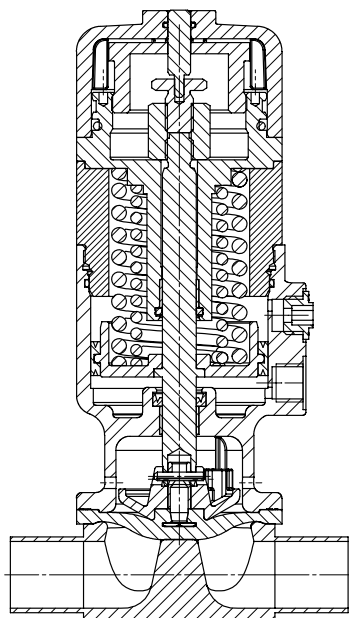

Technical data

Working medium

Corrosive, inert, gaseous and liquid media which have no negative impact on the physical and chemical properties of the body and diaphragm material.

The valve will seal in both flow directions up to full operating pressure (gauge pressure).

Temperatures

Medium temperature

drinks filling	-10 ... 85 °C
other applications	-10 ... 100 °C

Sterilisation temperature

EPDM (code 13/3A)	150 °C, max. 60 min
PTFE (code 52/5A)	Constant temperature* 150 °C

The sterilisation temperature is valid for steam or superheated water.

* The valves concerned must be serviced regularly if steam is applied continuously.

Ambient temperature

0 ... 60 °C

Control medium

Inert gases

Max. permissible temperature of control medium

60 °C

Filling volume

Actuator size	Control function 1	Control function 2+3
0	0.007 dm ³	0.006 dm ³
1	0.021 dm ³	0.010 dm ³
2	0.060 dm ³	0.038 dm ³

Actuator size Code	Diaphragm size	Operating pressure [bar]		Control pressure [bar]	
		EPDM	PTFE	C.f. 1	C.f. 2 + 3
0	8	0 - 5	0 - 5	5.0 - 7.0	max. 5.5
1	10	0 - 5	0 - 5	5.0 - 7.0	max. 7.0
2	25	0 - 5	0 - 5	4.0 - 7.0	max. 7.0

All pressures are gauge pressures. Operating pressure values were determined with static operating pressure applied on one side of a closed valve. Sealing at the valve seat and atmospheric sealing is ensured for the given values.
Information on operating pressures applied on both sides and for high purity media on request.

Kv values [m³/h]

MG	DN	DIN Code 0	DIN 11850 Series 1 Code 16	DIN 11850 Series 2 Code 17	DIN 11850 Series 3 Code 18	SMS 3008 Code 37	ASME BPE Code 59	EN ISO 1127 Code 60
8	4	0.5	-	-	-	-	-	-
	6	1.1	-	-	-	-	-	1.2
	8	1.3	-	-	-	-	0.6	2.2
	10	-	2.1	2.1	2.1	-	1.3	-
	15	-	-	-	-	-	2.0	-
10	10	-	2.4	2.4	2.4	-	2.2	3.3
	15	3.3	3.8	3.8	3.8	-	2.2	4.0
	20	-	-	-	-	-	3.8	-
25	15	4.1	4.7	4.7	4.7	-	-	7.4
	20	6.3	7.0	7.0	7.0	-	4.4	13.2
	25	13.9	15.0	15.0	15.0	12.6	12.2	16.2

Kv values determined acc. to IEC 534 standard, inlet pressure 6 bar, Δp 1 bar, stainless steel valve body and soft elastomer diaphragm.

Diagrams - Control function 2/3

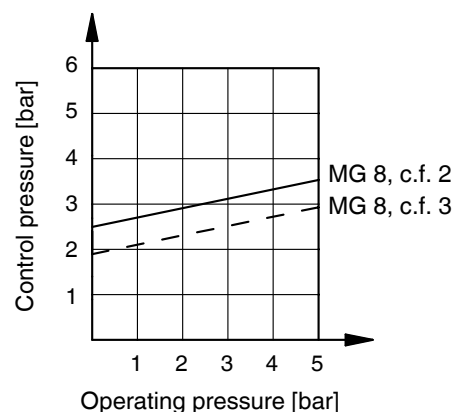
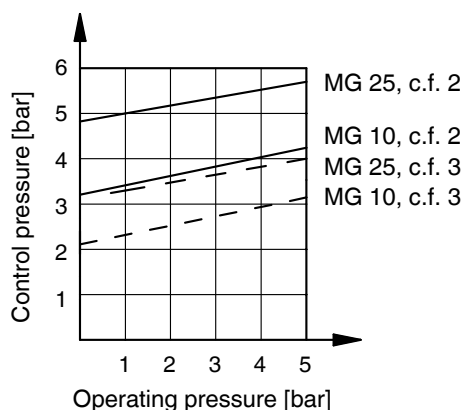

Order data

Body configuration	Code
Tank valve body	B**
2/2-way body	D
Multi-port design	M**
T body	T*
* For dimensions see T Valves brochure	
** Dimensions and versions on request	

Valve body material	Code
1.4435 - BN2 (CF3M), investment casting Fe<0.5%	32
1.4435 (ASTM A 351 CF3M, Δ 316L), investment casting	34
1.4408, investment casting	37
1.4435 (316L), forged body	40
1.4435 (BN2), forged body Fe<0.5%	42

Connection	Code
Butt weld spigots	
Spigots DIN	0
Spigots DIN 11850, series 1	16
Spigots DIN 11850, series 2	17
Spigots DIN 11850, series 3	18
Spigots DIN 11866, series A	1A
Spigots DIN 11866, series B	1B
Spigots JIS-G 3447	35
Spigots JIS-G 3459	36
Spigots SMS 3008	37
Spigots BS 4825, part 1	55
Spigots ASME BPE	59
Spigots EN ISO 1127	60
Spigots ANSI/ASME B36.19M, Schedule 10s	63
Spigots ANSI/ASME B36.19M, Schedule 40s	65
Threaded connections	
Threaded sockets DIN ISO 228	1
Threaded spigots DIN 11851	6
One side threaded spigot, other side cone spigot and union nut, DIN 11851	62
Aseptic unions on request	
Clamp connections	
Clamps ASME BPE for pipe ASME BPE, length ASME BPE	80
Clamps DIN 32676 series B for pipe EN ISO 1127, length EN 558, series 7	82
Clamps ASME BPE for pipe ASME BPE, length EN 558, series 7	88
Clamps DIN 32676 series A for pipe DIN 11850, length EN 558, series 7	8A
Clamps SMS 3017 for pipe SMS 3008, length EN 558, series 7	8E
Aseptic clamps on request	
Other connections on request	

Diaphragm material	Code
EPDM	13 3A*
PTFE/EPDM, PTFE lamin.	52 5A*
*for diaphragm size 8	
Material complies with FDA requirements	
For compatibility see overview on page 10	

Control function	Code
Normally closed (NC)	1
Normally open (NO)	2
Double acting (DA)	3

Actuator size	Code
Actuator size 0 (Diaphragm size 8)	0
Actuator size 1 (Diaphragm size 10)	1
Actuator size 2 (Diaphragm size 25)	2

Actuator version	Code
Control air connectors in flow direction	T
Control air connectors 90° offset to flow direction	R

Spring set	Code
Standard	1

For further order data see page 4

Valve body surface finish, internal contour

		Forged body Code 40, 42	Investment casting Code 32, 34	Code
Ra ≤ 6.3 µm	blasted internal/external	-	X	1500
Ra ≤ 6.3 µm	optical electropolishing	-	X	1509
Ra ≤ 0.8 µm	mechanically polished internal, blasted external	X	X	1502
Ra ≤ 0.8 µm	electropolished internal/external	X	-	1503
Ra ≤ 0.6 µm	mechanically polished internal, blasted external	X	X	1507
Ra ≤ 0.6 µm	electropolished internal/external	X	-	1508
Ra ≤ 0.4 µm	mechanically polished internal, blasted external	X	-	1536
Ra ≤ 0.4 µm	electropolished internal/external	X	-	1537
Ra ≤ 0.25 µm	mechanically polished internal, blasted external	X	-	1527
Ra ≤ 0.25 µm	electropolished internal/external	X	-	1516

Ra acc. to DIN 4768; at defined reference points
Surface finish data refer to medium wetted surfaces

Special function

Code

3-A compliant design

M

Order example	660	15	D	60	40	13	1	2	T	1	1503	M
Type	660											
Nominal size		15										
Body configuration (code)			D									
Connection (code)				60								
Valve body material (code)					40							
Diaphragm material (code)						13						
Control function (code)							1					
Actuator size (code)								2				
Actuator version (code)									T			
Spring set (code)										1		
Surface finish (code)											1503	
Special function (code)												M

Dimensions [mm]

Actuator dimensions											
MG	Control function	Actuator version	A	A1	A2	A4	B	B1	B2	G	Weight [kg]
8	1	T	109	50	21	4.5	38	28	28	M5	0.65
		R									
	2 + 3	T	92	50	21	4.5	38	28	28		
		R									
10	1	T	139	37	27	6.5	50	34	26	G 1/8	1.30
		R							37		
	2 + 3	T	120	37	27	6.5	50	34	26		
		R							37		
25	1	T	183	50	24	9.0	73	45	39	G 1/4	3.60
		R							51		
	2 + 3	T	148	50	24	9.0	73	45	39		
		R							51		

MG = diaphragm size

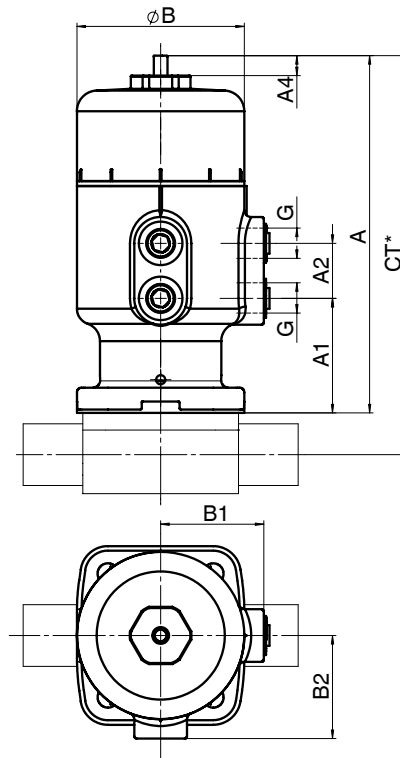

* CT = A + H1 (see body dimensions)

Body dimensions [mm]

Butt weld spigots, connection code 0, 16, 17, 18 Valve body material: Investment casting (code 34), forged body (code 40)

MG	DN	NPS	f*	øg*	L	c	H1*	H1**	DIN Series 0 Code 0		DIN 11850 Series 1 Code 16		DIN 11850 Series 2 Code 17		DIN 11850 Series 3 Code 18		Weight [kg]
									ød	s	ød	s	ød	s	ød	s	
8	4	-	-	-	72	20	8.5		6	1.0	-	-	-	-	-	-	0.09
	6	-	-	-	72	20	8.5		8	1.0	-	-	-	-	-	-	0.09
	8	1/4"	-	-	72	20	8.5		10	1.0	-	-	-	-	-	-	0.09
	10	3/8"	-	-	72	20	8.5		-	-	12	1.0	13	1.5	14	2.0	0.09
	15	1/2"	-	-	72	20	8.5		-	-	-	-	-	-	-	-	0.09
10	10	3/8"	30	13.5	108	25	12.5		-	-	12	1.0	13	1.5	14	2.0	0.30
	15	1/2"	30	13.5	108	25	12.5		18	1.5	18	1.0	19	1.5	20	2.0	0.30
	20	3/4"	30	13.5	108	25	12.5		-	-	-	-	-	-	-	-	0.30
25	15	1/2"	40	13.5	120	25	13.0	19.0	18	1.5	18	1.0	19	1.5	20	2.0	0.62
	20	3/4"	40	13.5	120	25	16.0	19.0	22	1.5	22	1.0	23	1.5	24	2.0	0.58
	25	1"	40	13.5	120	25	19.0	19.0	28	1.5	28	1.0	29	1.5	30	2.0	0.55

* only for investment cast design ** only for forged design MG = diaphragm size
For materials see overview on last page

Butt weld spigots, connection code 1A, 1B, 60 Valve body material: Investment casting (code 34), forged body (code 40)

MG	DN	NPS	f*	øg*	L	c	H1*	H1**	DIN 11866 Series A Code 1A		DIN 11866 Series B Code 1B		EN ISO 1127 Code 60		Weight [kg]
									ød	s	ød	s	ød	s	
8	4	-	-	-	72	20	8.5		-	-	-	-	-	-	0.09
	6	-	-	-	72	20	8.5		8	1.0	10.2	1.6	10.2	1.6	0.09
	8	1/4"	-	-	72	20	8.5		10	1.0	13.5	1.6	13.5	1.6	0.09
	10	3/8"	-	-	72	20	8.5		13	1.5	-	-	-	-	0.09
	15	1/2"	-	-	72	20	8.5		-	-	-	-	-	-	0.09
10	10	3/8"	30	13.5	108	25	12.5		13	1.5	17.2	1.6	17.2	1.6	0.30
	15	1/2"	30	13.5	108	25	12.5		19	1.5	21.3	1.6	21.3	1.6	0.30
	20	3/4"	30	13.5	108	25	12.5		-	-	-	-	-	-	0.30
25	15	1/2"	40	13.5	120	25	13.0	19.0	19	1.5	21.3	1.6	21.3	1.6	0.62
	20	3/4"	40	13.5	120	25	16.0	19.0	23	1.5	26.9	1.6	26.9	1.6	0.58
	25	1"	40	13.5	120	25	19.0	19.0	29	1.5	33.7	2.0	33.7	2.0	0.55

* only for investment cast design ** only for forged design MG = diaphragm size
For materials see overview on last page

Body dimensions [mm]

Butt weld spigots, connection code 35, 36, 37 Valve body material: Investment casting (code 34), forged body (code 40)

MG	DN	NPS	f*	øg*	L	c	H1*	H1**	JIS-G 3447 Code 35		JIS-G 3459 Code 36		SMS 3008 Code 37		Weight [kg]
									ød	s	ød	s	ød	s	
8	4	-	-	-	72	20	8.5		-	-	-	-	-	-	0.09
	6	-	-	-	72	20	8.5		-	-	10.5	1.20	-	-	0.09
	8	1/4"	-	-	72	20	8.5		-	-	13.8	1.65	-	-	0.09
	10	3/8"	-	-	72	20	8.5		-	-	-	-	-	-	0.09
	15	1/2"	-	-	72	20	8.5		-	-	-	-	-	-	0.09
10	10	3/8"	30	13.5	108	25	12.5		-	-	17.3	1.65	-	-	0.30
	15	1/2"	30	13.5	108	25	12.5		-	-	21.7	2.10	-	-	0.30
	20	3/4"	30	13.5	108	25	12.5		-	-	-	-	-	-	0.30
25	15	1/2"	40	13.5	120	25	13.0	19.0	-	-	21.7	2.10	-	-	0.62
	20	3/4"	40	13.5	120	25	16.0	19.0	-	-	27.2	2.10	-	-	0.58
	25	1"	40	13.5	120	25	19.0	19.0	25.4	1.2	34.0	2.80	25.0	1.2	0.55

* only for investment cast design ** only for forged design MG = diaphragm size
For materials see overview on last page

Butt weld spigots, connection code 55, 59, 63, 65 Valve body material: Investment casting (code 34), forged body (code 40)

MG	DN	NPS	f*	øg*	L	c	H1*	H1**	BS 4825 Code 55		ASME BPE Code 59		ANSI/ASME B36.19M 10s Code 63		ANSI/ASME B36.19M 40s Code 65		Weight [kg]
									ød	s	ød	s	ød	s	ød	s	
8	4	-	-	-	72	20	8.5		-	-	-	-	-	-	-	-	0.09
	6	-	-	-	72	20	8.5		-	-	-	-	10.3	1.24	10.3	1.73	0.09
	8	1/4"	-	-	72	20	8.5		6.35	1.2	6.35	0.89	13.7	1.65	13.7	2.24	0.09
	10	3/8"	-	-	72	20	8.5		9.53	1.2	9.53	0.89	-	-	-	-	0.09
	15	1/2"	-	-	72	20	8.5		12.70	1.2	12.70	1.65	-	-	-	-	0.09
10	10	3/8"	30	13.5	108	25	12.5		9.53	1.2	9.53	0.89	17.1	1.65	17.1	2.31	0.30
	15	1/2"	30	13.5	108	25	12.5		12.70	1.2	12.70	1.65	21.3	2.11	21.3	2.77	0.30
	20	3/4"	30	13.5	108	25	12.5		19.05	1.2	19.05	1.65	-	-	-	-	0.30
25	15	1/2"	40	13.5	120	25	13.0	19.0	-	-	-	-	21.3	2.11	21.3	2.77	0.62
	20	3/4"	40	13.5	120	25	16.0	19.0	19.05	1.2	19.05	1.65	26.7	2.11	26.7	2.87	0.58
	25	1"	40	13.5	120	25	19.0	19.0	-	-	25.40	1.65	33.4	2.77	33.4	3.38	0.55

* only for investment cast design ** only for forged design MG = diaphragm size
For materials see overview on last page

Body dimensions [mm]

Threaded sockets, connection code 1 Valve body material: investment casting (code 37)

MG	DN	R	H	H1	t	L	SW2	Number of flats	Weight [kg]
8	8	G 1/4	19	9	11	72	18	6	0.09
10	12	G 3/8	25	13	12	55	22	2	0.17
	15	G 1/2	30	15	15	68	27	2	0.26
25	15	G 1/2	29	16	15	85	27	6	0.32
	20	G 3/4	32	16	16	85	32	6	0.34
	25	G 1	37	16	13	110	41	6	0.39

MG = Diaphragm size

For materials see overview on last page

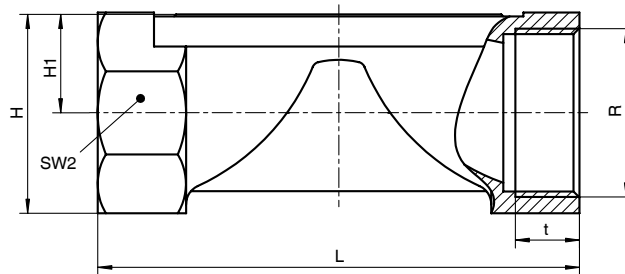

Threaded connections, connection code 6, 62 Valve body material: investment casting (code 34), forged body (code 40)

MG	DN	H1*	H1**	f*	øg*	ød1	Thread to DIN 405 R	Code 6 L	Code 62 L	Weight [kg]
8	10	8.5	-	-	-	10.0	RD 28 x 1/8	92	90	0.21
10	10	12.5	-	30.0	13.5	10.0	RD 28 x 1/8	118	116	0.33
	15	12.5	-	30.0	13.5	16.0	RD 34 x 1/8	118	116	0.35
25	15	13.0	19	40.0	13.5	16.0	RD 34 x 1/8	118	116	0.71
	20	16.0	19	40.0	13.5	20.0	RD 44 x 1/6	118	114	0.78
	25	19.0	19	40.0	13.5	26.0	RD 52 x 1/6	128	127	0.79

* only for investment cast design

** only for forged design

MG = diaphragm size

For materials see overview on page 9

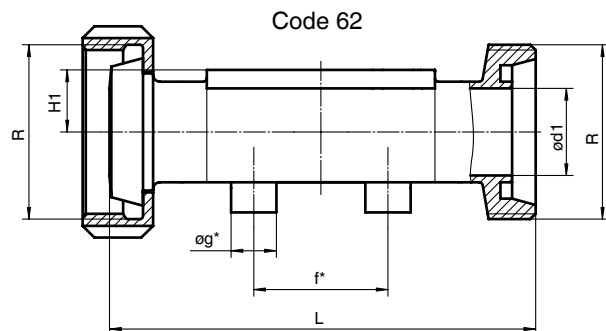
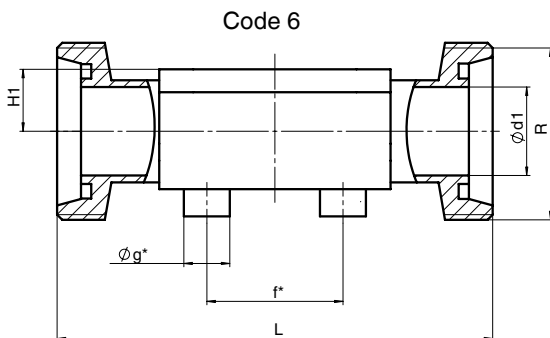

Body dimensions [mm]

Clamp connections, connection code 80, 82, 88, 8A, 8E Valve body material: forged body (code 40)

MG	DN	NPS	H1	for pipe ASME BPE Code 80			for pipe EN ISO 1127 Code 82			for pipe ASME BPE Code 88			for pipe DIN 11850 Code 8A			for pipe SMS 3008 Code 8E			Weight [kg]
				ød1	ød3	L	ød1	ød3	L	ød1	ød3	L	ød1	ød3	L	ød1	ød3	L	
8	6	1/8"	8.5	-	-	-	7.0	25.0	63.5	-	-	-	6	25.0	63.5	-	-	-	-
	8	1/4"	8.5	4.57	25.0	63.5	10.3	25.0	63.5	-	-	-	8	25.0	63.5	-	-	-	0.15
	10	3/8"	8.5	7.75	25.0	63.5	-	-	-	-	-	-	10	34.0	88.9	-	-	-	0.18
	15	1/2"	8.5	9.40	25.0	63.5	-	-	-	9.40	25.0	108	-	-	-	-	-	-	0.18
10	10	3/8"	12.5	-	-	-	14.0	25.0	108.0	-	-	-	10	34.0	108.0	-	-	-	0.30
	15	1/2"	12.5	9.40	25.0	88.9	18.1	50.5	108.0	9.40	25.0	108	16	34.0	108.0	-	-	-	0.43
	20	3/4"	12.5	15.75	25.0	101.6	-	-	-	15.75	25.0	117	-	-	-	-	-	-	0.43
25	15	1/2"	19.0	-	-	-	18.1	50.5	108.0	-	-	-	16	34.0	108.0	-	-	-	0.75
	20	3/4"	19.0	15.75	25.0	101.6	23.7	50.5	117.0	15.75	25.0	117	20	34.0	117.0	-	-	-	0.71
	25	1"	19.0	22.10	50.5	114.3	29.7	50.5	127.0	22.10	50.5	127	26	50.5	127.0	22.6	50.5	127	0.63

MG = diaphragm size

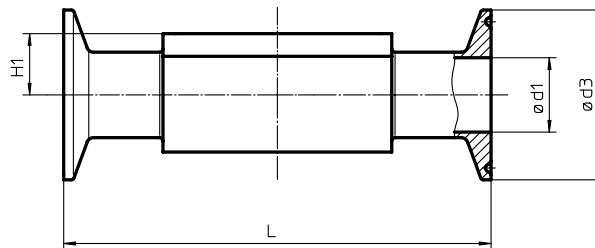

Overview of diaphragm materials for GEMÜ 660

Diaphragm material	EPDM	PTFE/EPDM
Diaphragm size		
8	3A	5A
10	13	52
25	13	52

Overview of valve bodies for GEMÜ 660

		Spigots																							
Connection code		0		16		17		18		1A	1B	35		36	37		55		59		60		63	65	
Material code		34	40	34	40	34	40	34	40	40	40	34	40	40	34	40	34	40	34	40	34	40	40	40	
MG	DN																								
8	4	X	X	-	-	-	-	-	-	-	-	-	-	-	-	-	-	-	-	-	-	-	-	-	-
	6	X	X	-	-	-	-	-	-	X	X	-	-	X	-	-	-	-	-	-	-	X	X	X	X
	8	X	X	-	-	-	-	-	-	X	X	-	-	X	-	-	X	X	X	X	X	X	X	X	X
	10	-	-	X	X	X	X	X	X	X	-	-	-	-	-	-	X	X	X	X	-	-	-	-	-
	15	-	-	-	-	-	-	-	-	-	-	-	-	-	-	-	X	X	X	X	-	-	-	-	-
10	10	-	-	X	X	X	X	X	X	X	X	-	-	X	-	-	-	X	-	X	X	X	X	X	X
	12	-	-	-	-	-	-	-	-	-	-	-	-	-	-	-	-	-	-	-	-	-	-	-	-
	15	X	X	X	X	X	X	X	X	X	X	-	-	X	-	-	X	X	-	X	X	X	X	X	X
	20	-	-	-	-	-	-	-	-	-	-	-	-	-	-	-	X	X	X	X	-	-	-	-	-
25	15	X	X	X	X	X	X	-	X	X	X	-	-	X	-	-	-	-	-	-	X	X	X	X	X
	20	X	X	X	X	X	X	-	X	X	X	-	-	X	-	-	X	X	X	X	X	X	X	X	X
	25	X	X	X	X	X	X	X	X	X	X	X	X	X	X	X	-	-	X	X	X	X	X	X	X

MG = diaphragm size

		Threaded connections					Clamp				
Connection code		1	6		62		80	82	88	8A	8E
Material code		37	34	40	34	40	40	40	40	40	40
MG	DN										
8	4	-	-	-	-	-	-	-	-	-	-
	6	-	-	-	-	-	-	K	-	K	-
	8	X	-	-	-	-	K	K	-	K	-
	10	-	W	W	W	W	K	-	-	W	-
	15	-	-	-	-	-	K	-	W	-	-
10	10	-	W	W	W	W	-	K	-	K	-
	12	X	-	-	-	-	-	-	-	-	-
	15	X	W	W	W	W	K	W	K	K	-
	20	-	-	-	-	-	K	-	K	-	-
25	15	X	W	W	W	W	-	W	-	K	-
	20	X	W	W	W	W	K	K	K	K	-
	25	X	W	W	W	W	K	K	K	K	K

X = Standard

K = Connections completely machined (not welded)

W = Welded construction MG = diaphragm size

Availability of material code 32 same as code 34, code 42 same as code 40

For further metal diaphragm valves, accessories and other products,
please see our Product Range catalogue and Price List.
Contact GEMÜ.

GEMÜ® VALVES, MEASUREMENT
AND CONTROL SYSTEMS

