

Diaphragm Valve, Metal

Construction

The GEMÜ 675 manually operated 2/2-way metal diaphragm valve has a non-rising handwheel and an integral optical position indicator as standard.

Features

- Suitable for inert and corrosive* liquid and gaseous media
- Insensitive to particulate media
- Valve body and diaphragm available in various materials and designs
- Various connections available
- Compact design (when space is at a premium)

Advantages

- Optional flow direction
- Installation for an optimized draining is possible

* see information on working medium on page 2



Sectional drawing

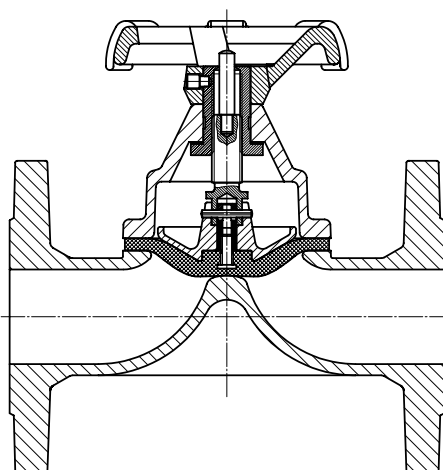

Technical data

Working medium

Corrosive, inert, gaseous and liquid media which have no negative impact on the physical and chemical properties of the body and diaphragm material.

Max. perm. temperature of working medium 150 °C
depending on medium, diaphragm and valve body material,
for more detailed information see our "Diaphragms" brochure.

Ambient conditions

Max. ambient temperature 60 °C

Diaphragm size	DN	Operating pressure [bar]		Kv Value [m³/h]	Weight [kg]	
		EPDM	PTFE		Connection code 1	Connection code 8
25	15	10	6.0	7	1.65	3.15
	20			14	1.70	3.70
	25			20	1.85	4.12
40	32	10	6.0	36	3.50	7.00
	40			40	3.75	7.90
50	50	10	6.0	80	5.25	10.40
65	65	10	6.0	100	-	16.20
80	80	10	6.0	160	-	23.40
100	100	10	6.0	238	-	33.80
125	125	10	6.0	376	-	50.00
150	150	8	5.0	496	-	62.00
200	200	5	3.0	964	-	155.00
250	250	4	2.5	1790	-	285.00
300	300	4	2.5	2240	-	335.00

All pressures are gauge pressures. Operating pressure values were determined with static operating pressure applied on one side of a closed valve. Sealing at the valve seat and atmospheric sealing is ensured for the given values.

Information on operating pressures applied on both sides and for high purity media on request.

Kv values determined acc. to IEC 534 standard, inlet pressure 6 bar, Δp 1 bar, valve body material cast iron EN-GJL-250 and flanges EN 1092 length EN 558-1 series 1 and soft elastomer diaphragm.

Bonnet dimensions GEMÜ 675 [mm]

MG	DN	ø B	A	Weight [kg]
25	15 - 25	90	87	1.0
40	32 + 40	118	109	1.8
50	50	128	127	2.7
65	65	188	171	5.9
80	80	188	196	7.6
100	100	238	227	11.3
125	125	316	300	15.0
150	150	316	325	25.0
200	200	408	471	76.0
250	250	585	646	148.0
300	300	700	764	155.0

MG = Diaphragm size

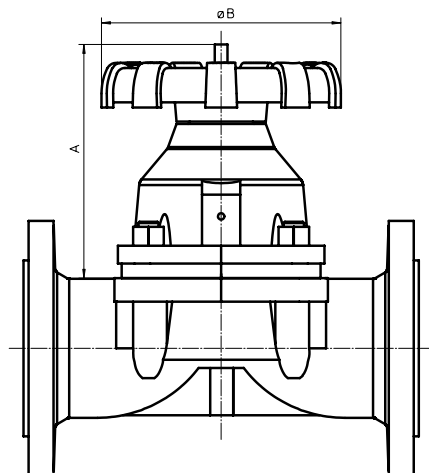

Order data

Body configuration	Code
2/2-way	D

Connection	Code
Threaded connections	
Threaded sockets DIN ISO 228	1
Flanges	
Flanges EN 1092 / PN16 / form B, length EN 558, series 1, ISO 5752, basic series 1	8
Flanges ANSI CLASS 150 RF, length MSS SP-88	38
Flanges ANSI CLASS 125/150 RF, length EN 558, series 1, ISO 5752, basic series 1	39
Flanges BS 10 Table "E", length EN 558, series 7, ISO 5752, basic series 7	51
Flanges EN 1092 / PN16 / form A, length EN 558, series 7, ISO 5752, basic series 7	53
Flanges ANSI CLASS 125/150 RF, length EN 558, series 7, ISO 5752, basic series 7	56
Flange ratings refer to flange class only. For valve operating pressures see Technical data on page 2.	

Valve body material	Code
EN-GJL-250 GG 25 (Cast iron)	8
EN-GJS-400-18-LT GGG 40.3 (SG iron) PFA lined	17
EN-GJS-400-18-LT GGG 40.3 (SG iron) PP lined	18
EN-GJS-500-7 GGG 50 (Ductile iron) PFA lined	81
EN-GJS-400-18-LT GGG 40.3 (SG iron) Hard rubber lined	83
EN-GJS-500-7 GGG 50 (Ductile iron) PP lined	91

Diaphragm material	Code
NBR	2
FPM	4
CR	8
EPDM, Ethylene Propylene Diene Monomer	14
PTFE/EPDM, fully laminated	52
PTFE/EPDM convex, PTFE loose	5E*

The combination of PFA or PTFE lining with 5E diaphragms is only conditionally suitable for gaseous media. If low seat leakage rates are required for gaseous media, other combinations are preferable.

*For use with valve bodies see page 6

Control function	Code
Manually operated	0
Manually operated with lockable handwheel (with padlock)	L
Manually operated with lockable handwheel (without padlock)	B

Order example	675	50	D	8	8	14	0
Type	675						
Nominal size		50					
Body configuration (code)			D				
Connection (code)				8			
Valve body material (code)					8		
Diaphragm material (code)						14	
Control function (code)							0

Other connections, valve body materials, linings and diaphragm materials on request.

Body dimensions [mm]

Threaded sockets - DIN ISO 228, connection code 1 Valve body material: GG 25 (code 8)

MG	DN	R	L	H	H1	t	SW2	Number of flats
25	15	G 1/2	85	35	19	12	32	6
	20	G 3/4	85	40	19	13	41	6
	25	G 1	110	42	19	16	46	6
40	32	G 1 1/4	120	56	28	16	55	6
	40	G 1 1/2	140	61	28	18	65	6
50	50	G 2	165	73	35	18	75	6

MG = diaphragm size

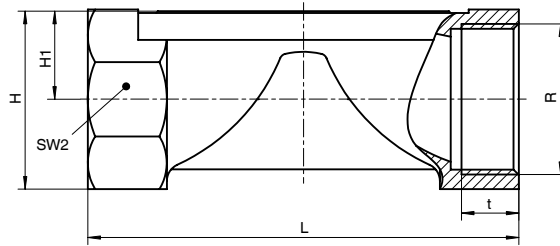

Flanges - DIN EN 1092, connection code 8, 53 Valve body material: GG 25 (code 8), GGG 40.3 (code 17, 18, 83)

						H1		FTF			
						Connection code 8		Connection code 53	EN 558, series 1 Connection code 8		EN 558, series 7 Connection code 53
MG	DN	øD	øk	øL	Number of bolt	Material code		Material code 8	Material code 8, 17, 18, 83	Material code	
						8	17, 18, 83			8	8
25	15	95	65	14	4	19,0	18,0	19,0	130	117	-
	20	105	75	14	4	19,0	20,5	19,0	150	117	-
	25	115	85	14	4	19,0	23,0	19,0	160	127	-
40	32	140	100	18	4	28,0	28,7	28,0	180	-	-
	40	150	110	18	4	28,0	33,0	28,0	200	159	-
50	50	165	125	18	4	35,0	39,0	35,0	230	191	-
65	65	185	145	18	4	27,5	51,0	27,5	290	216	-
80	80	200	160	18	8	33,0	59,5	33,0	310	254	-
100	100	220	180	18	8	43,0	73,0	43,0	350	305	-
125	125	250	210	18	8	65,0	87,0	65,0	400	356	-
150	150	285	240	23	8	58,0	109,0	58,0	480	406	416
200	200	340	295	23	8	-	-	88,0	-	521	-
250	250	400	350	23	12	-	-	120,5	-	635	-
300	300	455	400	23	12	-	-	142,5	-	749	-

For materials see overview on last page.

MG = diaphragm size

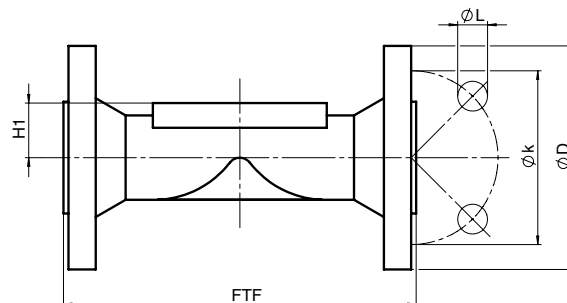

Body dimensions [mm]

Flanges - ANSI CLASS 125/150 RF, connection code 38, 39, 56
Valve body material: GG 25 (code 8), GGG 40.3 (code 17, 18, 83), GGG 50 (code 81, 91)

						H1			FTF			
						Connection code 38, 39		Connection code 56	MSS Sp-88 Connection code 38		EN 558 series 1 Connection code 39	similar to EN 558 series 7 Connection code 56
MG	DN	øD	øk	øL	Number of bolt	Material code 8	Material code 17, 18, 83	Material code 17, 81, 91	Material code 17, 18, 83		Material code 8, 17, 18, 83	Material code 17, 81, 91
25	15	90	60.3	15.9	4	19.0	18.0	-	-	-	130	-
	20	100	69.9	15.9	4	19.0	20.5	-	146	146.4	150	-
	25	110	79.4	15.9	4	19.0	23.0	23	146	146.4	160	127
40	32	115	88.9	15.9	4	28.0	28.7	-	-	-	180	-
	40	125	98.4	15.9	4	28.0	33.0	32	175	171.4	200	165
50	50	150	120.7	19.0	4	35.0	39.0	40	200	197.4	230	191
65	65	180	139.7	19.0	4	27.5	51.0	-	226	222.4	290	-
80	80	190	152.4	19.0	4	33.0	59.5	58	260	260.4	310	254
100	100	230	190.5	19.0	8	43.0	73.0	70	327	324.4	350	311
125	125	255	215.9	22.2	8	65.0	87.0	-	-	-	400	-
150	150	280	241.3	22.2	8	58.0	109.0	109	416	-	480	416
200	200	345	298.5	22.2	8	88.0	130.0	-	-	-	-	-
250	250	405	362.0	22.2	12	120.5	-	-	-	-	-	-
300	300	485	431.8	22.2	12	142.5	-	-	-	-	-	-

For materials see overview on last page.

MG = diaphragm size

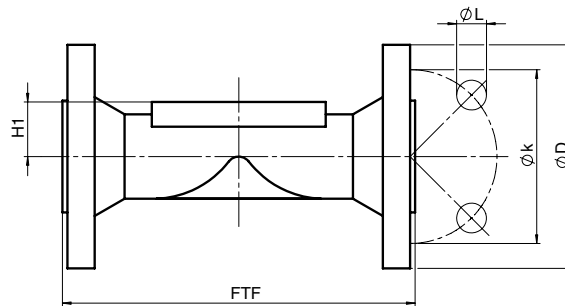

Flanges - BS 10 Table "E", connection code 51
Valve body material: GGG 40.3 (code 17), GGG 50 (code 81, 91)

Diaphragm size	DN	øD	øk	øL	Number of bolt	H1	FTF
25	25	114	83	14	4	23	127
40	40	133	98	14	4	32	165
50	50	152	114	17	4	40	191
80	80	184	146	17	4	58	254
100	100	216	178	17	8	70	311
150	150	279	235	22	8	109	416

For materials see overview on last page.

Overview of valve bodies for GEMÜ 675

		Threaded connections	Flanges																			
Connection code		1	8					38			39				51			53		56		
Material code		8	8	17	18	83	17	18	83	8	17	18	83	17	81	91	8	17	17	81	91	
MG	DN																					
	15	X	X*	X	X	X	-	-	-	X*	X	X	X	-	-	-	X*	-	-	-	-	
25	20	X	X*	X	X	X	X	X	X	X*	X	X	X	-	-	-	X*	-	-	-	-	
	25	X	X*	X	X	X	X	X	X	X*	X	X	X	-	X	X	X*	-	-	X	X	
40	32	X	X*	X	X	X	-	-	-	X*	X	X	X	-	-	-	-	-	-	-	-	
	40	X	X*	X	X	X	X	X	X	X*	X	X	X	-	X	X	X*	-	-	X	X	
50	50	X	X*	X	X	X	X	X	X	X*	X	X	X	-	X	X	X*	-	-	X	X	
65	65	-	X*	X*	X*	X*	X*	X*	X*	X*	X*	X*	X*	-	-	-	X*	-	-	-	-	
80	80	-	X*	X	X	X	X	X	X	X*	X	X	X	-	X	X	X*	-	-	X	X	
100	100	-	X*	X	X	X	X	X	X	-	X	X	X	-	X	X	X*	-	-	X	X	
125	125	-	X*	X	-	X	-	-	-	X*	X	-	X	-	-	-	X*	-	-	-	-	
150	150	-	X*	X	-	X	X	-	X	X*	X	-	X	X	-	-	X*	X	X	-	-	

Connection code 38 / material code 18 on request

*Valve bodies are not suitable for use with diaphragm code 5E

MG = diaphragm size

For further metal diaphragm valves, accessories and other products,
please see our Product Range catalogue and Price List. Contact GEMÜ.

GEMÜ® VALVES, MEASUREMENT
AND CONTROL SYSTEMS

