

## Multi-Port Globe Valve, Metal

### Construction

The GEMÜ 312/314 pneumatically operated 3/2-way valves have a rugged low maintenance aluminium piston actuator.

GEMÜ 312 is flanged, GEMÜ 314 has threaded sockets. The double sided valve plug is connected to the actuator via a spindle. The valve spindle is sealed by a self-adjusting gland packing providing low maintenance and reliable valve spindle sealing even after a long service life. A wiper ring fitted in front of the gland packing protects it against contamination and damage.

### Features

- Suitable for inert liquid and gaseous media
- Control medium: inert gases
- Suitable for high working medium temperatures
- Materials of wetted parts can be selected to suit relevant applications
- With GEMÜ 312 and GEMÜ 314 valves control processes which normally require two separate valves can be combined, for example: mixing, separating, aerating and de-aerating

### Advantages

- Accessories
- Simple adaptation for use as a control valve

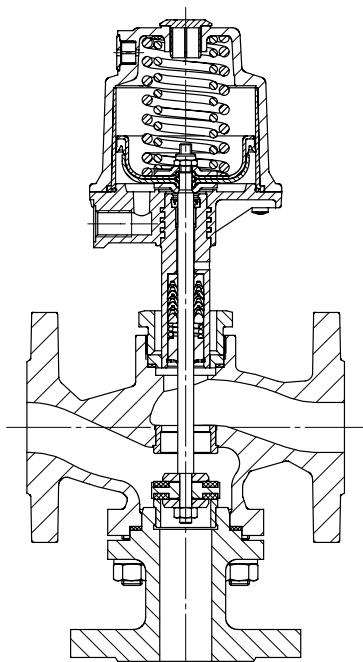
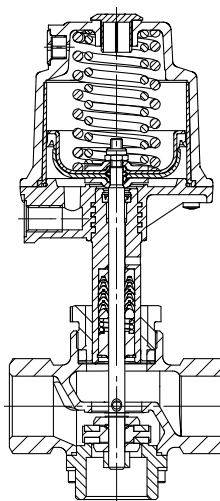
**GEMÜ 312****GEMÜ 314**

## Technical data

### Working medium

Inert, gaseous and liquid media which have no negative impact on the physical and chemical properties of the body and seal material.

Permissible pressure of working medium:  
see table below

Medium temperature -10°C to 180 °C  
(lower/higher temperatures on request)

### Control medium

Inert gaseous media

Control pressure see table below

Max. perm. temperature of control medium 60 °C

Filling volume Actuator 1 0.125 dm<sup>3</sup>  
Actuator 2 0.625 dm<sup>3</sup>

### Ambient conditions

Max. ambient temperature 60 °C

DN	Max. Operating pressure [bar]*		Control pressure [bar]		Kv value [m <sup>3</sup> /h]				Weight [kg]			
	Actuator 1	Actuator 2	Actuator 1	Actuator 2	GEMÜ 312		GEMÜ 314		Actuator 1		Actuator 2	
	P→A	P→A	The valve is closed from A to R		P→A	A→R	P→A	A→R	GEMÜ 312	GEMÜ 314	GEMÜ 312	GEMÜ 314
15	16.0	-	5.5 - 7.0	-	6.0	4.2	3.6	2.5	4.4	1.7	-	-
20	16.0	-	5.5 - 7.0	-	12.0	7.1	5.5	3.3	5.8	1.8	-	-
25	10.0	16.0	5.5 - 7.0	-	18.5	12.7	10.6	7.3	6.7	2.1	-	-
32	6.0	16.0	5.5 - 7.0	4.5 - 7.0	26.0	15.0	18.0	10.4	10.4	3.2	13.3	6.1
40	4.5	14.0	5.5 - 7.0	4.5 - 7.0	40.0	27.0	31.0	20.9	11.5	3.7	14.5	6.7
50	2.5	10.0	5.5 - 7.0	5.5 - 7.0	60.0	43.0	47.0	33.7	15.3	4.7	18.4	7.9
65	-	7.0	-	5.5 - 7.0	104.0	68.0	-	-	-	-	25.5	-
80	-	4.0	-	5.5 - 7.0	145.0	96.0	-	-	-	-	32.0	-
100	-	2.0	-	5.5 - 7.0	220.0	144.0	-	-	-	-	44.0	-

\*Operating pressure at connection R may not be greater than operating pressure P → A (see drawing on pages 4 and 5).

Kv values determined acc. to IEC 534 standard, valve body material cast iron EN-GJL-250 with connection flange EN 1092, valve body material cast bronze with threaded socket connection DIN ISO 228. The Kv value data refers to control function 1 (NC) and the largest actuator for each nominal size.

Kv values may be different for other combinations. Consult GEMÜ.

### Pressure / temperature correlation

Connection code	Material code	Max. allowable operating pressures in bar at temperature °C*					
		RT	100	150	200	250	300
8	8	16.0	16.0	14.4	12.8	11.2	9.6
1	9	16.0	16.0	16.0	13.5	-	-

\* The valves can be used down to -10°C RT = Room Temperature All pressures are gauge pressures.

### Functions

GEMÜ 312 Distribution

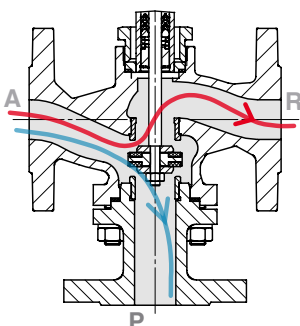

A - R  
A - P

GEMÜ 314 Distribution

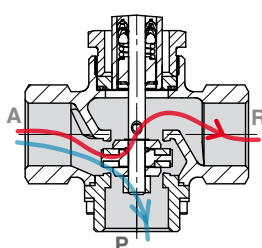

GEMÜ 312 Mixing

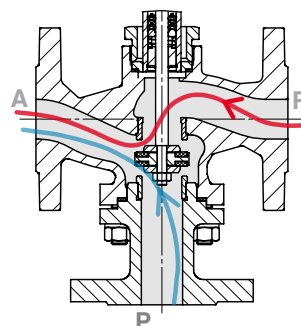

R - A  
P - A

## Order data

Body configuration	Code
Multi-port	M

Control function	Code
Normally closed (NC)	1
Other control functions on request	

Connection	Code
Threaded sockets DIN ISO 228 (GEMÜ 314)	1
Flanges EN 1092 / PN 16 / form B length EN 558, series 1, ISO 5752, basic series 1 (GEMÜ 312)	8
Flanges ANSI CLASS 125/150 RF length EN 558, series 1, ISO 5752, basic series 1 (GEMÜ 312)	39

Actuator size	Code
Actuator 1 piston ø 70 mm	1
Actuator 2 piston ø 120 mm	2

Valve body material	Code
GEMÜ 312: EN-GJL-250 (GG 25) Cast iron	8
GEMÜ 314: (Rg 5) CC499K, Cast bronze	9

Special versions	Code
Media temperature -10 to 210 °C (only with seat seal Code 5G and 10)	K-Nr. 2023

Seat seal	Code
PTFE	5
PTFE, glass reinforced	5G

**Note**  
Other versions on request.

Order example	312	20	M	8	8	5	1	1	-
Type	312								
Nominal size		20							
Body configuration (code)			M						
Connection (code)				8					
Valve body material (code)					8				
Seat seal (code)						5			
Control function (code)							1		
Actuator size (code)								1	
Special versions (code)									-

## Dimensions GEMÜ 312 [mm]

### Actuator dimensions

	$\varnothing B$	M	A2	G
Actuator size 1	96	M16 x 1	85.5	G 1/4
Actuator size 2	164	M22 x 1.5	123.0	G 1/4

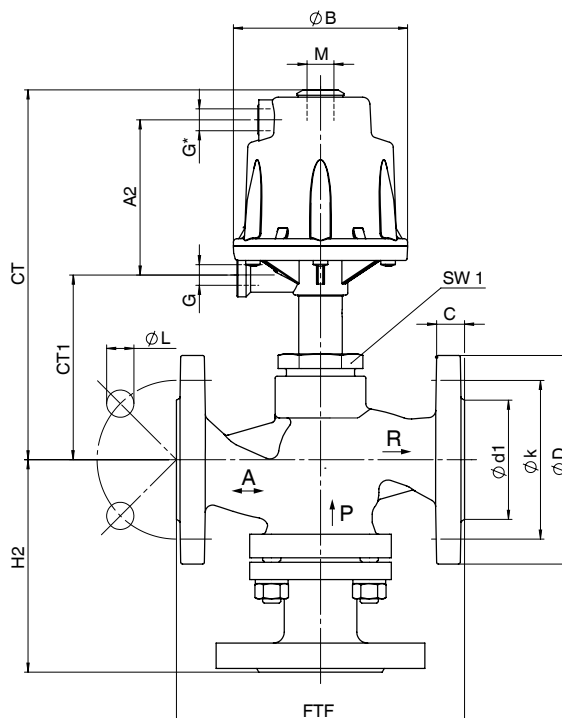

\*Connection only for control functions 2 and 3

### Body dimensions / Installation dimensions

#### Flanges - DIN EN 1092, connection code 8 Valve body material: GG 25 (code 8)

DN	FTF	$\varnothing D$	$\varnothing k$	$\varnothing L$	Number of bolts	SW1	$\varnothing d1$	C	H2	Actuator 1		Actuator 2	
										CT	CT1	CT	CT1
15	130	95	65	14	4	41	45	14	97	193	95	-	-
20	150	105	75	14	4	41	58	16	112	198	100	-	-
25	160	115	85	14	4	41	68	16	118	199	101	-	-
32	180	140	100	18	4	41	78	18	142	210	112	285	141
40	200	150	110	18	4	41	88	18	148	218	120	293	149
50	230	165	125	18	4	41	102	20	158	225	127	300	156
65	290	185	145	18	4	55	122	20	183	-	-	314	170
80	310	200	160	18	8	55	138	22	204	-	-	326	182
100	350	220	180	18	8	55	158	24	236	-	-	339	195

#### Flanges - ANSI CLASS 125/150 RF, connection code 39 Valve body material: GG 25 (code 8)

DN	FTF	$\varnothing D$	$\varnothing k$	$\varnothing L$	Number of bolts	SW1	$\varnothing d1$	C	H2	Actuator 1		Actuator 2	
										CT	CT1	CT	CT1
15	130	90	60.3	15.9	4	41	35.1	11.2	97	193	95	-	-
20	150	100	69.9	15.9	4	41	42.9	12.7	112	198	100	-	-
25	160	110	79.4	15.9	4	41	50.8	14.2	118	199	101	-	-
32	180	115	88.9	15.9	4	41	63.5	15.7	142	210	112	285	141
40	200	125	98.4	15.9	4	41	73.2	17.5	148	218	120	293	149
50	230	150	120.7	19.0	4	41	91.9	19.1	158	225	127	300	156
65	290	180	139.7	19.0	4	55	104.6	22.4	183	-	-	314	170
80	310	190	152.4	19.0	4	55	127.0	23.9	204	-	-	326	182
100	350	230	190.5	19.0	8	55	157.2	23.9	236	-	-	339	195

## Dimensions GEMÜ 314 [mm]

### Actuator dimensions

	$\varnothing B$	M	A2	G
Actuator size 1	96	M16 x 1	85.5	G 1/4
Actuator size 2	164	M22 x 1.5	123.0	G 1/4

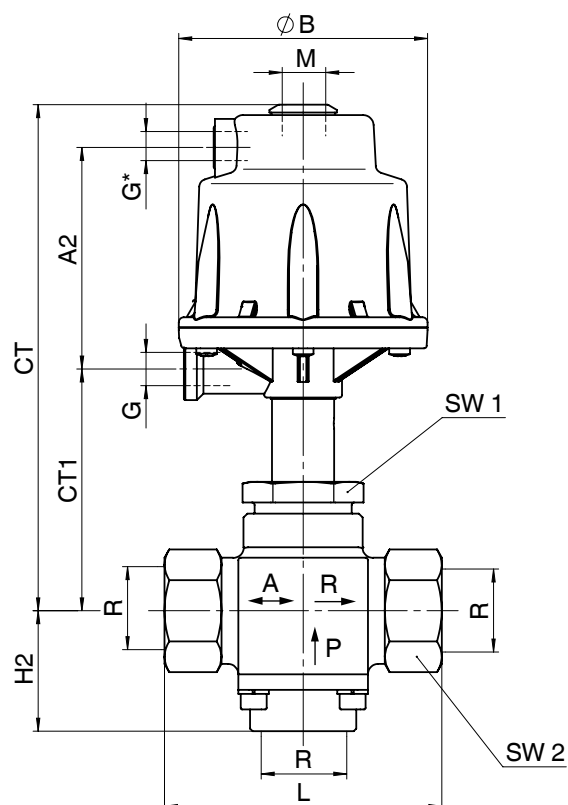

\*Connection only for control functions 2 and 3

## Body dimensions / Installation dimensions

Threaded sockets, connection code 1  
Valve body material: Cast bronze (code 9)

DN	R	L	SW1	SW2	H2	Actuator 1		Actuator 2	
						CT	CT1	CT	CT1
15	G 1/2	75	36	27	41	186	88	-	-
20	G 3/4	87	36	32	46	190	92	-	-
25	G 1	107	41	41	47	190	92	-	-
32	G 1 1/4	123	55	50	66	194	96	269	125
40	G 1 1/2	147	55	58	68	194	96	269	125
50	G 2	171	55	70	74	198	100	273	129

## Overview of valve bodies - GEMÜ 312, 314

Connection code	1 (GEMÜ 314)	8 (GEMÜ 312)	39 (GEMÜ 312)
Material code	9	8	8
DN 15	X	X	X
DN 20	X	X	X
DN 25	X	X	X
DN 32	X	X	X
DN 40	X	X	X
DN 50	X	X	X
DN 65	-	X	X
DN 80	-	X	X
DN 100	-	X	X

All rights including copyright and industrial property rights are expressly reserved.

## Other multi-port globe valves



GEMÜ 342 / 344



GEMÜ 352 / 354



Should there be any doubts or misunderstandings, the German version of this data sheet is the authoritative document!

For further globe valves, accessories and other products, please see our Product Range catalogue and Price List.  
Contact GEMÜ.

Subject to alteration · 10 / 2015 · 88048809

**GEMÜ**® VALVES, MEASUREMENT  
AND CONTROL SYSTEMS

