

Construction

The GEMÜ 1434 μ Pos® is a digital electro-pneumatic positioner for process valve control. Designed for simple, safe and quick use with valves with strokes < 25 mm. The positioner, travel sensor, switching valves and status LEDs are integrated in a solid compact housing with transparent cover. Pneumatic and electrical connections are in one mounting direction to save space and enable easy access.

Features

- Simple use and operation
- Direct or remote positioner mounting to the process valve
- For single acting normally open or normally closed linear actuators
- Multiple point calibration for optimum valve adaption
- Optimized initialisation and valve control

Advantages

- No air consumption when idle
- Simple mounting to various valve actuators
- Simple commissioning due to automatic initialisation
- **speed^{AP}** function for fast mounting and initialisation
- Simple operation, no settings necessary

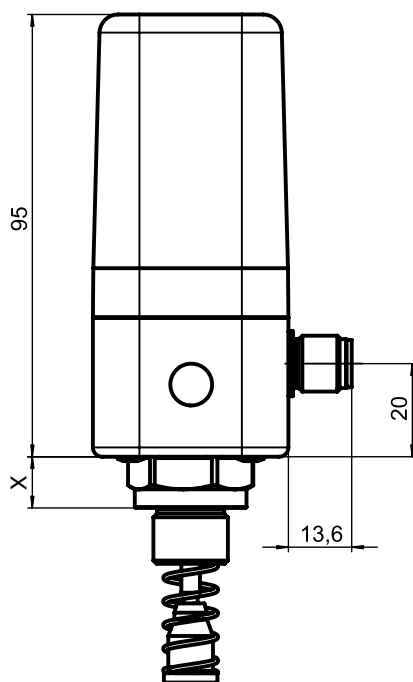
**Dimensional drawing [mm]**

Technical data

General information

Protection class to EN 60529	IP 65 / IP 67 ¹⁾
Weight	220 g
Dimensions L x W x H	See dimensional drawing
Mounting position	Optional
Intended use	For mounting to and control of pneumatic process valves
Particulars	Fail safe function in case of power supply failure ²⁾

Directives

EC low voltage	2006/95/EG
EMV directive	2004/108/EG

Conformities

Interference resistance	DIN EN 61000-6-2 (March 2006)
Interference emission	DIN EN 61000-6-4 (Sep. 2011) Interference emission class A Interference emission group 1

¹⁾ IP 67 rating applies when using piped air outlets. Replace threaded plug connectors 3 and 4 by M5 adapters (1434 000 Z2, 2 pieces required) for this purpose.

²⁾ the air supply line of the process valve is vented in case of power supply failure.

Operating conditions

Ambient temperature	0 to +60 °C
Storage temperature	-10 to +60 °C
Control medium	Quality classes to DIN ISO 8573-1
Dust content	Class 3 (max. particle size 5 µm) (max. particle density 5 mg/m ³)
Pressure dew point	Class 3 (max. pressure dew point -20 °C)
Oil concentration	Class 3 (max. oil concentration 1 mg/m ³)
Air supply	1 to 10 bar at 40 °C 1 to 8 bar at 60 °C
Air consumption	0 l/min (when idle)
Air output	15 NI/min

Materials

Housing cover	Polypropylene (UV-stabilized)
Housing base	Anodized aluminium or stainless steel

Travel sensor system - integrated for direct mounting

Linear version

Stroke	0.8 to 10 mm (code 010) 2.0 to 25 mm (code 030)
Resistance R	1 / 3 kΩ
Minimum stroke	≥ 8% of travel length

Electrical data

Power supply

Power supply	$U_V = 18...30$ V DC
Power consumption	≤ 4 W (up to 24 V DC)

Analogue inputs

Accuracy / Linearity	≤ ± 0,3 % F.S.
Temperature drift	≤ ± 0.3 % F.S.
Set value	a) 0-10 V; b) 0/4...20 mA
Input	passive
Input resistance	a) 100 kΩ; b) 50 Ω
Resolution	12 bit
External travel sensor	$R_G = 1-10$ kΩ

Initialisation input (digital)

Voltage	$U_{rated} = 24$ V DC
Level "Logical 1"	14 V DC ≤ U_H ≤ 30 V DC
Level "Logical 0"	0 V DC ≤ U_L ≤ 8 V DC
Input current	$I_{typ} = 1.3$ mA (at 24 V DC)

Analogue output (optional)

Accuracy / Linearity	≤ ± 1.0 % F.S.
Temperature drift	≤ ± 0.5 % F.S.
Resolution	12 bit
Actual value output	0 - 20 mA / 4 - 20 mA load resistor max. 600 Ω, 0-10 V active

Output

Electrical connection

Power supply and signal connections	1 x M12 plug (A-coded) (Installation: Observe operating instructions)
-------------------------------------	--

Positioner data

System deviation	≤ 1%
Initialisation	Automatic via 24 V DC signal
Close tight function	CLOSED: W ≤ 0.5%; OPEN: W ≥ 99.5%

Display elements

Status display	4 visible LEDs
----------------	----------------

* Interferences on set value signal may influence control activities

Regulation diagram

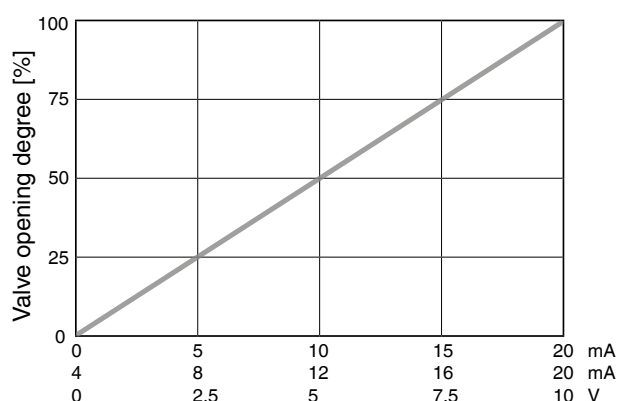

During initialisation the 1434 µPos automatically detects the actuator control function (Normally Open or Normally Closed). For all valves the Closed position is at 0/4mA or 0v.

Dimensions [mm]

Direct mounting

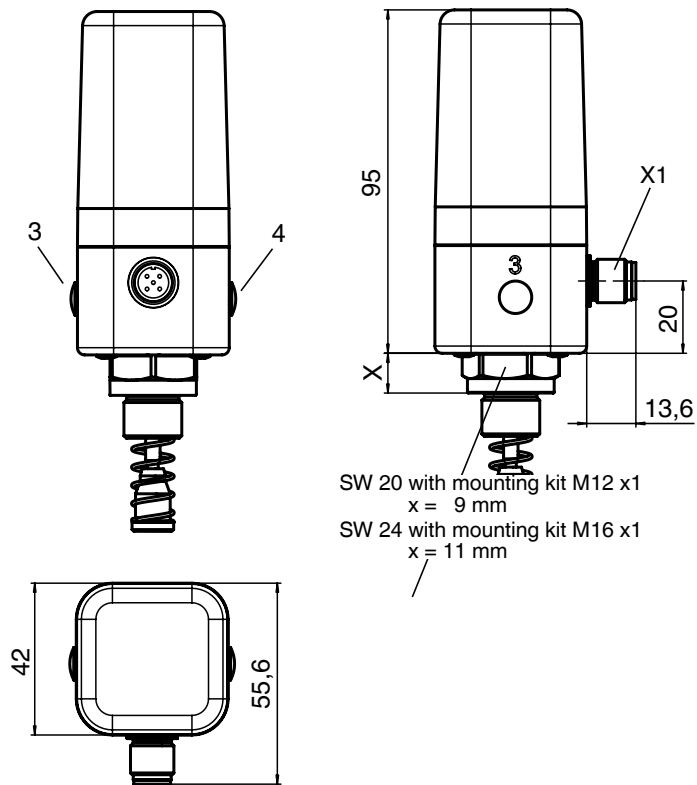

Remote mounting

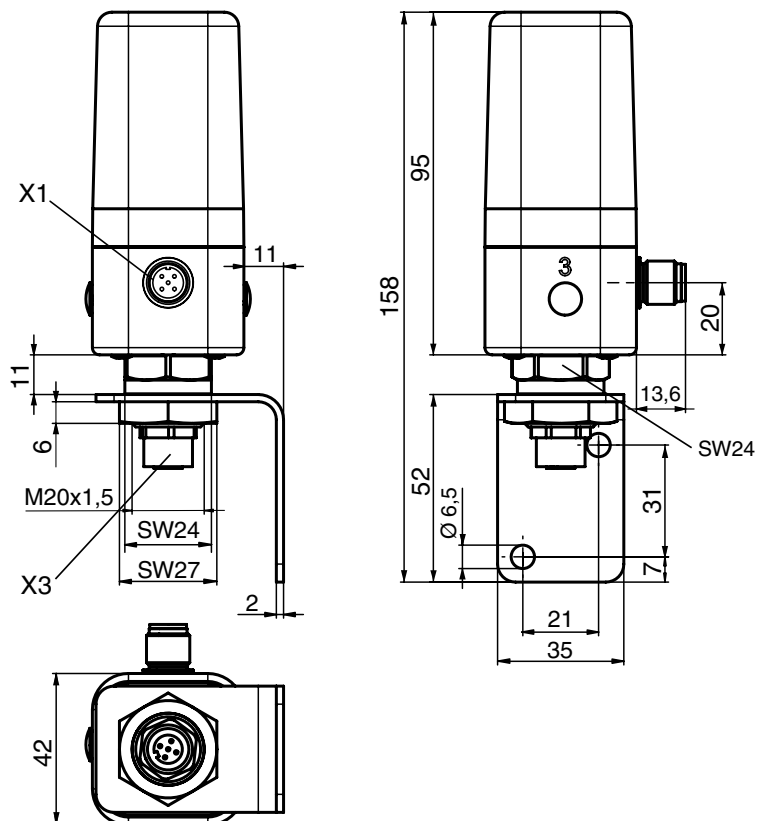

Connections and display elements

Electrical connection

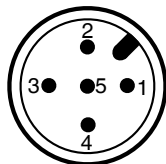
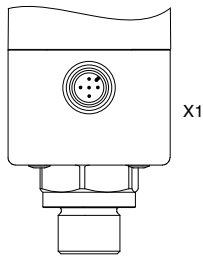

X 1
A-coded
M12 plug

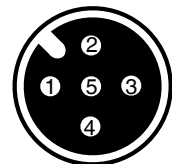
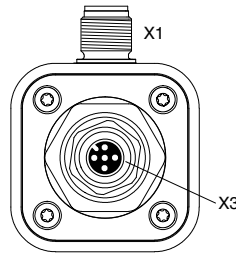

X 3
A-coded
M12 socket

Pin	Signal name
1	U_V , 24 V DC supply voltage
2	$I+ / U+$, 4-20 mA / 0-20 mA / 0-10 V (set value input)
3	U_V , I- / U- GND
4	$I+ / U+$, 4-20 mA / 0-20 mA / 0-10 V (actual value output-optional)
5	U_V , initialisation 24 V DC, initialisation is started by an impulse signal $t \geq 100$ ms

Pin	Signal name
1	UP+, output potentiometer supply voltage (+)
2	UP, input potentiometer wiper voltage
3	UP-, output potentiometer supply voltage (-)
4	n. c.
5	n. c.

X3 is only required in combination with an external travel sensor system.

For connection cables >30m install precautionary measures against surge voltage.

Remote mounting

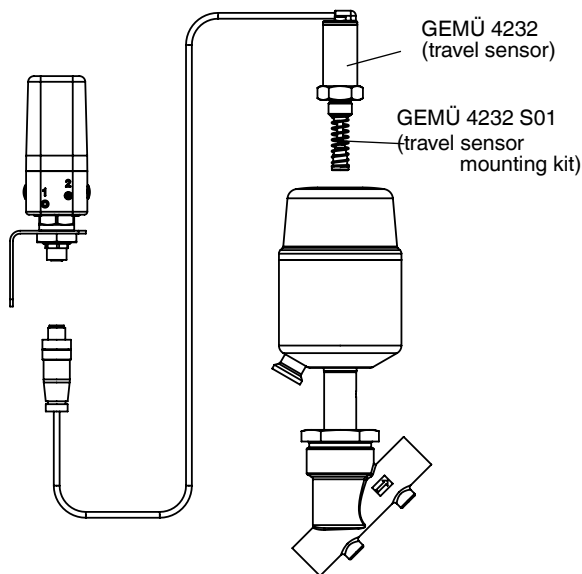

Direct mounting

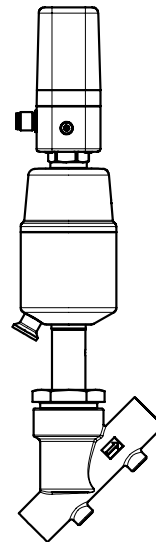

Pneumatic connection

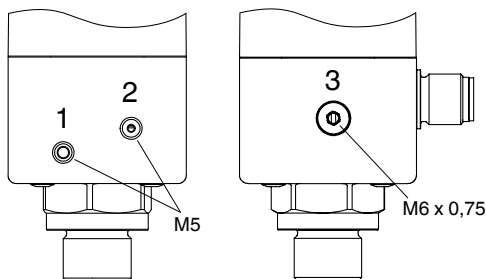

Connection	Description
1	Air supply connection P (max. 10 bar)
2	Working connection for process valve A1
3	Venting connection R with integrated check valve

Display elements

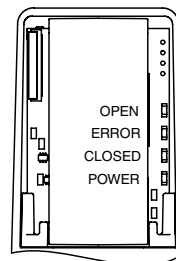

LED	Description	Colour
1	OPEN	yellow
2	ERROR	red
3	CLOSED	orange
4	POWER	yellow

Connection	Description
1	Air supply connection P (max. 10 bar)
2	Working connection for process valve A1
3	Venting connection R

Order data

Field bus	Code
Without (3-wire version)	000

Accessory	Code
Accessory	Z

Action	Code
Single acting, air exhaust	1

Set value input	Code
4-20 mA set value input	A
0-20 mA set value input	B
0-10 V set value input	C

Material	Code
Aluminium base, PP cover	14
Stainless steel base, PP cover	07

Pneumatic connection	Code
Air supply / output via M5 connection thread	1
Air supply / output via push-in connector, angle, 4 mm	2
Air supply / output via push-in connector, angle, 6 mm	3

Option	Code
Without	00
4-20 mA actual value output	A0
0-20 mA actual value output	B0
0-10 V actual value output	C0

Flow rate	Code
15 NI/min	01

Travel sensor version	Code
Potentiometer, 10 mm length	010
Potentiometer, 30 mm length	030
Potentiometer external, M 12 connector, (max. cable length 30 m)	S01

Order example	1434	000	Z	1	A	14	3	00	01	010
Type	1434									
Field bus (code)		000								
Accessory (code)			Z							
Action (code)				1						
Set value input (code)					A					
Material (code)						14				
Pneumatic connection (code)							3			
Option (code)								00		
Flow rate (code)									01	
Travel sensor version (code)										010

Note: Mounting kit 1434 S01 Z.../4232 S01 Z... depends on the valve type. Please order separately specifying valve type, DN and control function. Observe mounting kit travel length. A fitting and pneumatic tubing for the valve is included with each positioner with pneumatic connection (code 2 and 3).

The photo on page 1 shows the GEMÜ 1434 µPos® positioner with mounting kit.

Required parts for direct mounting
GEMÜ 1434...010/030 (positioner)
GEMÜ 1434 S01 Z... (travel sensor mounting kit)
GEMÜ 1219... (connector socket)

Required parts for remote mounting
GEMÜ 1434...S01 (positioner)
GEMÜ 4232 S01 Z... (travel sensor mounting kit)
GEMÜ 4232 000 Z... 4001 (travel sensor)
GEMÜ 1434 000 Z MP (mounting bracket)
GEMÜ 1219... (connector socket)

For further positioners, accessories and other products, please see our Product Range catalogue and Price List. Contact GEMÜ.

GEMÜ® VALVES, MEASUREMENT
AND CONTROL SYSTEMS

